

 | LA MARCA PARA LA INDUSTRIA

ACCESORIOS Y SUMINISTROS PARA MAQUINADO



www.westontools.com.mx

CATÁLOGO

20**22**



Árbol para Broquero CAT 40 e ISO 40



Código	Zanco	Conicidad
SA-015-0030	CAT40	JT6
SA-015-0040	CAT40	JT3
SA-015-0050	ISO40	JT6
SA-015-0060	CAT40	JT33

Árbol para Broquero R8



Código	Conicidad
SA-015-0510	JT1
SA-015-0520	JT5
SA-015-0530	JT33
SA-015-0540	JT3
SA-015-0550	JT6
SA-015-0560	JT4
SA-015-0570	MT1
SA-015-0580	MT3

Árbol Zanco Recto para Broquero

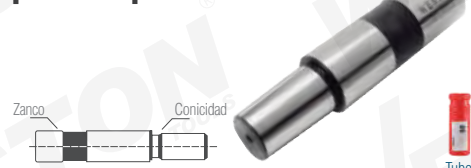

Código	Zanco	Conicidad
SA-015-0070	1/2"	JT1
SA-015-0080	1/2"	JT2
SA-015-0100	1/2"	JT33
SA-015-0110	1/2"	JT6
SA-015-0120	1/2"	JT3
SA-015-0200	1/2"	JT4
SA-015-0220	1/2"	JT5
SA-015-0090	5/8"	JT3
SA-015-0130	5/8"	JT1
SA-015-0150	5/8"	JT33
SA-015-0160	5/8"	JT5
SA-015-0170	5/8"	JT6
SA-015-0140	3/4"	JT3
SA-015-0180	3/4"	JT5
SA-015-0190	3/4"	JT6
SA-015-0210	3/4"	JT4
SA-015-0230	3/4"	JT33
SA-015-0240	1"	JT3
SA-015-0250	1"	JT33
SA-015-0260	1"	JT5
SA-015-0270	1"	JT6
SA-015-0280	1"	JT4

Árbol Zanco Cónico para Broquero

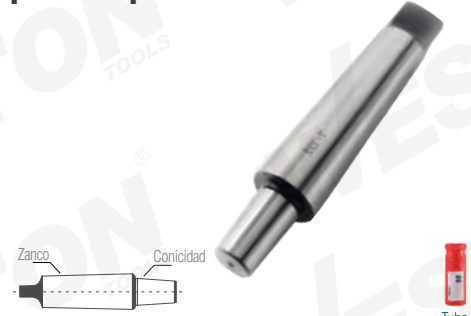

Código	Zanco	Conicidad
SA-015-0290	MT1	JT33
SA-015-0300	MT1	JT6
SA-015-0310	MT1	JT1
SA-015-0320	MT2	JT1
SA-015-0330	MT2	JT2
SA-015-0340	MT2	JT3
SA-015-0350	MT2	JT33
SA-015-0360	MT2	JT6
SA-015-0370	MT2	JT4
SA-015-0380	MT3	JT1
SA-015-0390	MT3	JT2
SA-015-0400	MT3	JT3
SA-015-0410	MT3	JT5
SA-015-0420	MT3	JT33
SA-015-0430	MT3	JT6
SA-015-0440	MT3	JT4
SA-015-0450	MT4	JT5
SA-015-0460	MT4	JT1
SA-015-0470	MT4	JT33
SA-015-0480	MT4	JT3
SA-015-0490	MT4	JT6
SA-015-0500	MT4	JT4

Adaptador Zanco R8



Código	Conicidad
SA-015-0590	MT1
SA-015-0600	MT2
SA-015-0610	MT3

Boquilla R8 Fraccional



Código	Medida	Código	Medida
SA-025-0010	1/8"	SA-025-0110	3/4"
SA-025-0020	3/16"	SA-025-0120	13/16"
SA-025-0030	1/4"	SA-025-0130	7/8"
SA-025-0040	5/16"	SA-025-0140	15/16"
SA-025-0050	3/8"	SA-025-0150	1"
SA-025-0060	7/16"	SA-025-0160	Juego de 1/8 - 7/8"
SA-025-0070	1/2"	SA-025-0170	7 piezas en 8avos
SA-025-0080	9/16"		Juego de 1/8 - 7/8"
SA-025-0090	5/8"		13 piezas en 8avos
SA-025-0100	11/16"		

Boquilla Cono Morse

Reducción de cono morse
Acero endurecido
Gran precisión
DIN 2185

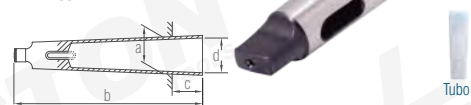

Código	Exterior C. M.	Interior C. M.	a	b	c	d	Medidas en mm
SA-015-0620	2	1	17.78	92	17	12.065	
SA-015-0630	3	1	23.825	99	5	12.065	
SA-015-0640	3	2	23.825	112	18	17.78	
SA-015-0650	4	1	31.267	124	6.5	12.065	
SA-015-0660	4	2	31.267	124	6.5	17.78	
SA-015-0670	4	3	31.267	140	22.5	23.825	
SA-015-0680	5	1	44.399	156	6.5	12.065	
SA-015-0690	5	2	44.399	156	6.5	17.78	
SA-015-0700	5	3	44.399	156	6.5	23.825	
SA-015-0710	5	4	44.399	171	21.5	31.267	
SA-015-0720	6	4	63.348	218	8	31.267	
SA-015-0730	6	5	63.348	218	8	44.399	

Boquilla R8 Métrica



Código	Medida	Código	Medida
SA-024-9000	3 mm	SA-024-9040	11 mm
SA-024-9005	4 mm	SA-024-9045	12 mm
SA-024-9010	5 mm	SA-024-9050	13 mm
SA-024-9015	6 mm	SA-024-9055	14 mm
SA-024-9020	7 mm	SA-024-9060	15 mm
SA-024-9025	8 mm	SA-024-9065	16 mm
SA-024-9030	9 mm	SA-024-9070	18 mm
SA-024-9035	10 mm	SA-024-9075	20 mm

Boquilla 5C Fraccional



Código	Medida	Código	Medida
SA-025-0180	1/8"	SA-025-0280	7/8"
SA-025-0190	3/16"	SA-025-0290	15/16"
SA-025-0200	1/4"	SA-025-0300	1"
SA-025-0210	5/16"	SA-025-0310	1 - 1/16"
SA-025-0220	5/8"	SA-025-0320	Juego de 1/8" - 1"
SA-025-0230	3/8"		15 piezas en 16avos
SA-025-0240	7/16"	SA-025-0330	Juego de 1/16" a 1-1/8"
SA-025-0250	3/4"		35 piezas en 16 y 32avos y medida estándar
SA-025-0260	1/2"		
SA-025-0270	9/16"		

Boquilla Redonda ER16 Fraccional



Código	Medida
SA-025-0680	1/16"
SA-025-0690	3/32"
SA-025-0700	1/8"
SA-025-0710	5/32"
SA-025-0720	3/16"
SA-025-0730	1/4"
SA-025-0740	5/16"
SA-025-0750	3/8"

ACCESORIOS PARA MAQUINADO

Boquilla Redonda ER20 Fraccional



MIN: 1 / CAJA: 200

Código	Medida
SA-025-0780	1/16"
SA-025-0790	3/32"
SA-025-0800	1/8"
SA-025-0810	5/32"
SA-025-0820	3/16"
SA-025-0830	1/4"
SA-025-0840	5/16"
SA-025-0850	3/8"

Boquilla Redonda Tipo ER25 Fraccional



MIN: 1 / CAJA: 150

Código	Medida
SA-025-0865	1/16"
SA-025-0867	3/32"
SA-025-0870	1/8"
SA-025-0880	3/16"
SA-025-0890	1/4"
SA-025-0900	5/16"
SA-025-0910	3/8"
SA-025-0920	7/16"
SA-025-0930	1/2"

Boquilla Redonda ER32 Fraccional



Código	Medida	Código	Medida
SA-025-0955	1/16"	SA-025-1060	1/2"
SA-025-0960	3/32"	SA-025-1070	17/32"
SA-025-0970	1/8"	SA-025-1080	9/16"
SA-025-0980	3/16"	SA-025-1090	5/8"
SA-025-0990	7/32"	SA-025-1100	21/32"
SA-025-1000	1/4"	SA-025-1110	11/16"
SA-025-1010	5/16"	SA-025-1120	3/4"
SA-025-1020	11/32"	SA-025-1130	25/32"
SA-025-1030	3/8"		
SA-025-1040	13/32"		
SA-025-1050	7/16"		

Boquilla Redonda ER40 Fraccional



MIN: 1 / CAJA: 80

Código	Medida	Código	Medida
SA-025-1155	1/16"	SA-025-1230	9/16"
SA-025-1157	3/32"	SA-025-1240	5/8"
SA-025-1160	1/8"	SA-025-1250	11/16"
SA-025-1170	3/16"	SA-025-1260	3/4"
SA-025-1180	1/4"	SA-025-1270	13/16"
SA-025-1190	5/16"	SA-025-1280	7/8"
SA-025-1200	3/8"	SA-025-1290	15/16"
SA-025-1210	7/16"	SA-025-1300	1"
SA-025-1220	1/2"		

Boquilla Redonda ER40 Métrica



Código	Medida	Código	Medida
SA-025-2000	3mm	SA-025-2055	14mm
SA-025-2005	4mm	SA-025-2060	15mm
SA-025-2010	5mm	SA-025-2065	16mm
SA-025-2015	6mm	SA-025-2070	17mm
SA-025-2020	7mm	SA-025-2075	18mm
SA-025-2025	8mm	SA-025-2080	19mm
SA-025-2030	9mm	SA-025-2085	20mm
SA-025-2035	10mm	SA-025-2090	21mm
SA-025-2040	11mm	SA-025-2095	22mm
SA-025-2045	12mm	SA-025-2100	23mm
SA-025-2050	13mm	SA-025-2105	24mm

Boquilla OZ25 Fraccional



Código	Medida	Código	Medida
SA-025-0336	1/16"	SA-025-0390	7/16"
SA-025-0338	3/32"	SA-025-0400	1/2"
SA-025-0340	1/8"	SA-025-0410	9/16"
SA-025-0350	3/16"	SA-025-0420	5/8"
SA-025-0360	1/4"	SA-025-0430	3/4"
SA-025-0370	5/16"	SA-025-0440	7/8"
SA-025-0380	3/8"	SA-025-0445	1"

Boquilla OZ25 Métrica



Código	Medida	Código	Medida
SA-025-0450	1mm	SA-025-0540	11mm
SA-025-0460	3mm	SA-025-0550	12mm
SA-025-0470	4mm	SA-025-0560	14mm
SA-025-0480	5mm	SA-025-0580	16mm
SA-025-0490	6mm	SA-025-0600	18mm
SA-025-0500	7mm	SA-025-0620	20mm
SA-025-0510	8mm	SA-025-0640	22mm
SA-025-0520	9mm	SA-025-0660	24mm
SA-025-0530	10mm	SA-025-0670	25mm

Boquilla TG100 Fraccional



MIN: 1 / CAJA: 15

Código	Medida	Código	Medida
SA-025-1320	1/8"	SA-025-1380	1/2"
SA-025-1330	3/16"	SA-025-1390	9/16"
SA-025-1340	1/4"	SA-025-1400	5/8"
SA-025-1350	5/16"	SA-025-1410	3/4"
SA-025-1360	3/8"	SA-025-1420	7/8"
SA-025-1370	7/16"	SA-025-1425	1"

Juego de Boquillas

Incluye estuche



Código	Tipo	Piezas	Rango de boquillas	Con holder
SA-025-0675	OZ25	15	3 a 25mm	No
SA-025-1315	ER40	15	3 a 26mm	No
SA-025-0448	OZ25	15	1/8" a 1"	No
SA-025-0950	ER25	10	1/8" a 5/8"	No
SA-025-1150	ER32	12	3/32" a 3/4"	No
SA-025-1310	ER40	15	1/8" a 1"	No
SA-025-1317	ER40	15	1/8" a 1"	R8
SA-025-1570	ER40	15	1/8" a 1"	CAT40
SA-025-1730	ER40	15	1/8" a 1"	CAT50
SA-025-1800	ER40	15	1/8" a 1"	ISO40
SA-025-1900	ER40	15	1/8" a 1"	ISO50

Charola Plástica para Boquilla R8



Código	Capacidad
SA-305-0040	11 piezas

Charola Metálica para Boquilla R8



MIN: 1 / CAJA: 10

Código	Capacidad
SA-305-0050	15 piezas

Portaboquilla Zanco 3/4"



Código	Para boquilla
SA-020-0002	ER 16
SA-020-0004	ER 20
SA-020-0006	ER 25

ACCESORIOS PARA MAQUINADO

Portaboquilla R8

Para acoplar al eje de la fresadora y sujetar boquillas



MIN: 1 / CAJA: 16

Código	Para boquilla	Rosca de sujeción
SA-020-0010	OZ-25	7/16"-20
SA-020-0020	ER20	7/16"-20
SA-020-0030	ER25	7/16"-20
SA-020-0040	ER32	7/16"-20
SA-020-0041	ER32	M12 -1.75
SA-020-0050	ER40	7/16"-20

Portaboquilla ISO 40

Para acoplar al eje de la fresadora y sujetar boquillas
Rosca de sujeción: 5/8"-11
Cono ISO 40

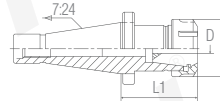

Código	Para boquilla	D	L1
SA-020-0060	ER20	34 mm	60 mm
SA-020-0070	ER25	42 mm	60 mm
SA-020-0080	ER32	50 mm	70 mm
SA-020-0090	ER40	63 mm	60 mm
SA-020-0100	ER50	78 mm	100 mm

Portaboquilla CAT 40

Para acoplar al eje de la fresadora y sujetar boquillas
Rosca de sujeción: 5/8"-11



Código	Para boquilla
SA-020-0105	ER16
SA-020-0110	ER20 x 3"
SA-020-0120	ER25
SA-020-0130	ER32
SA-020-0140	ER40
SA-020-0240	ER20 x 8"
SA-020-0250	ER25 x 3"
SA-020-0260	ER32 x 8"
SA-020-0270	ER40 x 3"
SA-020-0272	ER40 x 4"
SA-020-0280	ER25 x 10"
SA-020-0290	ER40 x 8"
SA-020-0300	ER40 G6

Portaboquilla CAT 50

Para acoplar al eje de la fresadora y sujetar boquillas



Código	Para boquilla	Rosca de sujeción
SA-020-0150	ER40	1"-8
SA-020-0150-1	ER40	1"-8
SA-020-0150-2	ER40	1"-8
SA-020-0160	ER40 G6	5/8"-11

Portaboquilla BT 30

Para acoplar al eje de la fresadora y sujetar boquillas



Código	Para boquilla
SA-020-0170	ER16 M12 x 1.75
SA-020-0180	ER32 M12 x 1.75

Portaboquilla BT 40

Para acoplar al eje de la fresadora y sujetar boquillas



Código	Para boquilla
SA-020-0190	OZ25 M16 x 2
SA-020-0200	ER20 M16 x 2
SA-020-0210	ER25 M16 x 2
SA-020-0220	ER32 M16 x 2
SA-020-0320	ER40 70 mm

Portaboquilla BT 50

Para acoplar al eje de la fresadora y sujetar boquillas



Código	Para boquilla
SA-020-0230	ER40 M4 x 3
SA-020-0310	ER40-80

Tuerca para Portaboquillas



Código	Para boquillas
SA-022-0010	ER40B con balero
SA-022-0020	ER11
SA-022-0030	ER16
SA-022-0040	ER20
SA-022-0050	ER25
SA-022-0060	ER32
SA-022-0070	OZ25

Llave para Portaboquilla



Código	Para tuerca
SA-024-0010	ER16
SA-024-0015	ER16M
SA-024-0020	ER20
SA-024-0030	ER25
SA-024-0040	ER32
SA-024-0045	ER40
SA-024-0050	OZ25

Tornillo de Retención

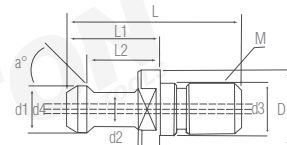

Código	Cono	a°	L	L1	L2	D	d1	d2	d3	d4	M	MIN	CAJA
SA-026-0008	BT30 x 60°	60	43	23	18	16.5	11	7	12.5	/	M12	1	-
SA-026-0010	BT40 x 60°	60	60	35	28	23	15	10	17	/	M16	1	100
SA-026-0020	MAZAK BT40	45	44.1	19.1	14	22	18.8	12.45	17	7	M16	1	-
SA-026-0030	MAZAK CAT40	45	44.1	16.1	11	22	18.8	12.45	17	7	M16	1	150
SA-026-0040	MAZAK CAT40	45	44.1	16.1	11	22	18.8	12.45	17	7	5/8"-11	1	200
SA-026-0050	CAT40 x 38	45	38.1	16.26	11.18	23.8	18.8	12.45	/	7.14	5/8"-11	1	150
SA-026-0060	CAT50 x 58	45	58.42	25.4	17.78	36	28.96	20.83	/	11.89	1"-8	1	50
SA-026-0070	CAT40 x 57	45	57	32	25	23	15	10	/	/	5/8"-11	1	200
SA-026-0080	CAT50 x 78.6	45	78.6	45	35.2	38	23	17	/	/	1"-8	1	-

Tornillo de Retención



Tornillo de Retención

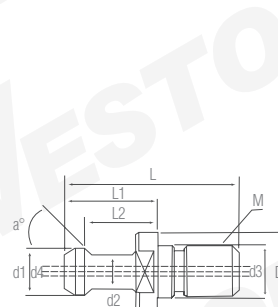

Código	Cono	a°	L	L1	L2	D	d1	d2	d3	d4	M
SA-500-2830	SK40	15	54	26	/	23	19	14	17	/	M16

ACCESORIOS PARA MAQUINADO

Cono con Broquero Integrado Ajustable



Código	Rango de Capacidad	MIN: 1 / CAJA: 10	Cono
● SA-010-0450	1/32"-1/2"		BT 40
SA-010-0460	1/8" -5/8"		BT 40

Cono CAT 40 para Cortador Vertical



Código	Medida	Tubo
SA-048-0080	1/8"	
SA-048-0090	3/16"	
SA-048-0100	1/4"	
SA-048-0110	5/16"	
SA-048-0120	3/8"	
SA-048-0130	7/16"	
SA-048-0140	1/2"	
SA-048-0150	5/8"	
SA-048-0160	3/4"	
SA-048-0170	7/8"	
SA-048-0180	1"	
SA-048-0190	1-1/4"	
● SA-048-0200	1-1/2"	

Cono CAT 50 para Cortador Vertical



Código	Medida	Tubo
● SA-048-0210	1/8"	
● SA-048-0220	3/16"	
● SA-048-0230	1/4"	
● SA-048-0240	5/16"	
SA-048-0250	3/8"	
SA-048-0260	1/2"	
● SA-048-0270	5/8"	
SA-048-0280	3/4"	
● SA-048-0290	7/8"	
SA-048-0300	1"	
SA-048-0310	1-1/4"	
SA-048-0320	1-1/2"	

Cono BT 40 para Cortador Vertical



Código	Medida	Tubo
SA-048-0440	1/8"	
SA-048-0450	3/16"	
SA-048-0460	3/8"	
SA-048-0470	1/4"	
SA-048-0480	1/2"	
SA-048-0500	3/4"	
SA-048-0510	7/8"	
SA-048-0520	1"	
SA-048-0530	1-1/4"	
SA-048-0540	1-1/2"	

Cono BT 50 para Cortador Vertical



Código	Medida	Tubo
● SA-048-0550	1/8"	
● SA-048-0560	3/16"	
● SA-048-0570	1/4"	
● SA-048-0580	3/8"	
● SA-048-0590	1/2"	
● SA-048-0600	5/8"	
● SA-048-0620	7/8"	

Broquero R8



Recomendado para fresadora



Código	Capacidad	Tubo
SA-010-0410	1/2"	
SA-010-0430	5/8"	

MIN: 1 / CAJA: 10

Portaherramienta para Cortador Vertical R8



Código	Medida	Tubo
● SA-048-0010	3/8"	
SA-048-0030	5/8"	
● SA-048-0040	3/4"	
SA-048-0045	7/8"	
SA-048-0050	1"	
SA-048-0060	1-1/4"	
● SA-048-0070	1-1/2"	

Broquero Plástico Montaje de Rosca



No incluye llave



Código	Capacidad	Montaje	MIN	CAJA
SA-010-0010	3/8"	3/8"-24	1	50
SA-010-0020	1/2"	1/2"-20	1	40
SA-010-0030	1/2"	3/8"-24	1	-

Super Broquero Embalado con Llave



Recomendado para banco ligero, medio y rudo, portátil o montado en el piso, en herramientas eléctricas



Código	Equivalente Jacobs	Capacidad	Montaje	MIN	CAJA
SA-010-0190	14N	1/2"	JT33	1	20
SA-010-0200	16N	5/8"	JT3	1	20
SA-010-0210	18N	3/4"	JT4	1	10

Broquero Ajustable Cónico



Recomendado para CNC que trabaja a máquina centro



Código	Capacidad	Montaje	MIN	CAJA	MASTER
SA-010-0340	1/2"	JT33	1	20	18
SA-010-0350	3/8"	JT33	1	20	25
SA-010-0360	5/8"	JT6	1	20	-
SA-010-0370	5/8"	JT3	1	20	18
SA-010-0380	3/4"	JT3	1	20	-
SA-010-0400	1/4"	JT1	1	-	-

Broquero de Sujeción Rosca con Llave



Entrada con rosca
Incluyen una llave
Garantizan excelente precisión y durabilidad
Recomendados para uso en general, con taladros eléctricos, de mesa, piso y convencionales



Código	Capacidad	Montaje	MIN	CAJA
SA-010-0040	1/2"	3/8"-24 UNF	1	40
SA-010-0050	1/2"	1/2"-20 UNF	1	40
SA-010-0060	3/8"	3/8"-24 UNF	1	-
SA-010-0070	3/8"	1/2"-20 UNF	1	50
SA-010-0090	1/4"	3/8"-24 UNF	1	20
SA-010-0110	5/8"	1/2"-20 UNF	1	20

Broquero con Llave



Uso rudo
Entrada cónica sin rosca
Garantizan excelente precisión y durabilidad
Recomendados para banco ligero, medio y rudo, portátil o piso y herramientas eléctricas



Código	Capacidad	Montaje	MIN: 1 / CAJA: 20
SA-010-0100	1/2"	JT33	
SA-010-0120	5/8"	JT6	
SA-010-0130	5/8"	JT3	
SA-010-0140	3/4"	JT3	
SA-010-0150	1/2"	JT6	
SA-010-0160	5/8"	JT33	
SA-010-0170	3/4"	JT4	

Juego de Broquero para Joyero

Capacidad
0-1mm
8-15mm
1.3-3.1mm
3-4.8mm



Broquero con Soporte Simple de Sujeción Cónica con Llave

Mordazas centradas para una absoluta rectitud y alineación
Manga de una sola pieza con estriado estándar

*Uso pesado

Código	Modelo	Rango de Capacidad	Montaje	Llave	Dimensiones de longitud Cerrado	Dimensiones de longitud Abierto	Diámetro de manga
*SA-012-0030	34 - 02	1 - 13 mm	2JT	K3	89.4	69.6	51.8
*SA-012-0040	34 - 33	1 - 13 mm	33JT	K3	89.4	69.6	51.8
*SA-012-0050	36KD	5 - 20.3 mm	3JT	K4	108	86.9	64.5
SA-012-0180	0	0 - 4 mm	0JT	K0	36.8	27.9	21.6
SA-012-0190	1A	1 - 6.5 mm	1JT	K1	48.8	39.1	30
SA-012-0200	2A	1 - 10 mm	2JT	K2	71.4	55.1	42.4
*SA-012-0220	3A	3 - 16 mm	3JT	K3	96.8	72.9	58.4
*SA-012-0230	33	2 - 13 mm	33JT	K32	81.53	63.5	45.52
*SA-012-0270	34 - 06	1 - 13 mm	6JT	K3	89.4	69.6	51.8
*SA-012-0280	36	0 - 20.3 mm	3JT	K4	103.1	49.8	64.5



Medidas en mm

Código	Contenido
SA-305-0190	Juego de 4 piezas

ACCESORIOS PARA MAQUINADO

Broquero Embalado de Sujeción Cónica con Llave

El embalado da mayor fuerza de agarre y precisión
Mordazas centradas para una absoluta rectitud y alineación
Manga de una sola pieza con estriado estándar
Los dientes endurecidos de la manga y la cerradura templada, proporcionan una excelente resistencia al desgaste



Medidas en mm

Código	Modelo	Rango de Capacidad	Montaje	Llave	Dimensiones de longitud Cerrado	Dimensiones de longitud Abierto	Diámetro de manga
SA-012-0060	14N	0 - 13 mm	3JT	K3	98.6	75.4	62.1
SA-012-0070	16N	3 - 16 mm	3JT	K4	109.5	82.8	66.9
SA-012-0080	18N	3.0 - 19.0 mm	4JT	K4	130	100.3	76.4
SA-012-0090	20N	10 - 25.4 mm	5JT	K5	139.7	107.4	92.6

Broquero con Soporte Simple de Sujeción Rosca con Llave

El embalado da mayor fuerza de agarre y precisión
Mordazas centradas para una absoluta rectitud y alineación
Manga de una sola pieza con estriado estándar
Los dientes endurecidos de la manga y la cerradura templada, proporcionan una excelente resistencia al desgaste



Medidas en mm

Código	Modelo	Rango de Capacidad	Montaje	Llave	Dimensiones de longitud Cerrado	Dimensiones de longitud Abierto	Diámetro de manga
SA-012-0210	2BA 3/8	1 - 10 mm	3/8"-24	K2	71	55	42
SA-012-0240	33BA 3/8	2 - 13 mm	3/8"-24	K32	78	62	45
SA-012-0250	33BA 1/2	2 - 13 mm	1/2"-20	K32	78	62	45
SA-012-0260	33BA 5/8	2 - 13 mm	5/8"-16	K32	78	62	45

Broquero Multi-Craft® con Llave

Cuenta con endurecido de las mordazas
Ideal para taladros eléctricos con cable o inalámbricos, reversibles



Medidas en mm

Código	Modelo	Rango de Capacidad	Montaje	Llave	Dimensiones de longitud Cerrado	Dimensiones de longitud Abierto	Diámetro de manga
SA-012-0100	30247D	1.5 - 10 mm	3/8"-24	-	59.68	46.98	32.89
SA-012-0110	30602	2 - 13 mm	1/2"-20	KK	73.4	56.63	41

Broquero Alta Precisión Sujeción Cónica

El montaje cónico Jacobs permite su uso en una amplia gama de prensas con taladro de alta precisión, plantillas barrenadoras, fresadoras y equipos de perforación
Para aplicaciones mecánicas en general
Sin llave



Medidas en mm

Código	Modelo	Rango de Capacidad	Montaje	Dimensiones de longitud Cerrado	Dimensiones de longitud Abierto	Diámetro de manga
SA-012-0290	JKP 100-J2	0.5 - 10 mm	2JT	89	81	41
SA-012-0300	JKP 130-J6	1 - 13 mm	6JT	99	88	46
SA-012-0310	JKP 160-J6	3 - 16 mm	6JT	107	95	55

Llave para Broqueros

Los estilos con apoyo de níquel para pulgar aumentan el apalancamiento y la comodidad del usuario
Las agarraderas con acero suave limitan el potencial de fractura peligrosa bajo una carga excesiva
Los modelos de auto-expulsión con resortes eyectores aseguran la desconexión de la llave después del apriete



Llaves para Broqueros



Palanca para el pulgar



Palanca T



Código	Modelo	Medida	Tipo de palanca	Se usa en:
SA-012-0010	K3	5/16"	Para el pulgar	3, 34 y 14N
SA-012-0020	K32	1/4"	Para el pulgar	32, 33 y 11N
SA-012-0120	KG1	1/4"	Palanca T	Multi-Craft® (palanca negra) 1/4" y 3/8"
SA-012-0130	KK	9/32"	Palanca T	DC8, SM8, 74K, 22BA, 23BA, 24BA, 26BA, 29-33, 30246, 30598, 30602, 31052
SA-012-0140	K1	5/32"	Palanca T	Serie 1
SA-012-0150	K2	1/4"	Para el pulgar	Serie 2
SA-012-0160	K4	3/8"	Para el pulgar	36, 16, 18N
SA-012-0170	K5	7/16"	Palanca T	20N

Código	Descripción	Medidas	Modelo
● SA-010-0240	Tipo L	1/4"	-
● SA-010-0330	4 en 1	1/4", 3/8" 5/16", 1/2"	-

Broquero de 1/2" para Taladro Magnético

Mordazas centradas para una rectitud y alineación absolutas
Compatible con cualquier máquina con zanco Weldon
Ideal para uso con taladros magnéticos



Código	Capacidad	Zanco	Altura (A)	Ancho (B)
SA-010-0500	1/2"	Weldon 3/4"	87mm	31mm

Punto Giratorio de Precisión

Para una sujeción precisa de piezas en tornos convencionales y CNC
De gran desempeño

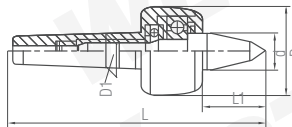

Código	Cono morse	Capacidad máxima de carga	Velocidad Máxima	Precisión	L	D	L1	d	D1
SA-110-0060	MT1	80 kg	7,000 RPM	0.01	124mm	36mm	27mm	15mm	12.065mm
SA-110-0010	MT2	140 kg	7,000 RPM	0.005	139mm	45mm	34mm	20mm	17.780mm
SA-110-0020	MT3	400 kg	5,000 RPM	0.005	176.5mm	60mm	47mm	25mm	23.825mm
SA-110-0030	MT4	500 kg	3,800 RPM	0.005	217mm	70mm	53mm	32mm	31.267mm
SA-110-0040	MT5	1,200 kg	3,000 RPM	0.005	273mm	90mm	65mm	40mm	44.399mm
SA-110-0050	MT6	2,500 kg	2,600 RPM	0.01	354.5mm	105mm	78mm	50mm	63.348mm

Punto Giratorio Estándar

Para una sujeción precisa de piezas en tornos convencionales y CNC

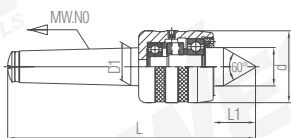

Código	Cono morse	Capacidad de carga radial	Velocidad	Exactitud	L	D	L1	d	D1
SA-110-0070	MT1	91 kg	5,000 Rpm	0.01	115mm	34mm	20mm	18mm	12mm
SA-110-0080	MT2	152 kg	5,000 Rpm	0.008	145mm	45mm	26mm	25mm	17.7mm
SA-110-0100	MT3	203 kg	4,200 Rpm	0.008	170mm	52mm	30mm	28mm	23.8mm
SA-110-0120	MT4	326 kg	3,200 Rpm	0.008	205.7mm	60mm	34.7mm	32mm	31.2mm
SA-110-0140	MT5	642 kg	2,000 Rpm	0.012	254mm	77mm	45mm	45mm	44.3mm
SA-110-0160	MT6	1,019 kg	1,600 Rpm	0.012	354mm	125mm	68.5mm	75mm	63.3mm



Punto Giratorio con Puntas Intercambiables



Código	Cono Morse
SA-110-0090	MT2
SA-110-0110	MT3
SA-110-0130	MT4
SA-110-0150	MT5

Punto Giratorio Tipo Pera

Los puntos han sido diseñados para sujetar el tubo y para trabajos ahuecados
Buen empuje y capacidades radiales
Cabeza con ángulo de 60°

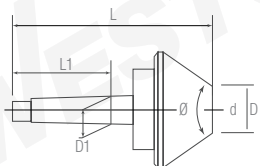

Código	Cono morse	Máx RPM	Concentricidad	Carga máxima	Peso	L	L1	D	D1	d	θ
SA-110-0170	MT3	3,300rpm	0.008mm	400kg	3kg	162mm	81mm	91mm	23.825mm	25	60°
SA-110-0180	MT4	2,000Rpm	0.012mm	650kg	9.9kg	212mm	102.5mm	140mm	31.267mm	40	60°
SA-110-0190	MT5	1,900Rpm	0.012mm	800kg	11.6kg	259mm	129.5mm	160mm	44.399mm	40	60°
SA-110-0200	MT6	1,600Rpm	0.015mm	1,500kg	21kg	313mm	182mm	200mm	63.348mm	66	60°



También contamos con...



Moletadores

Acero rectificado mecanizado en acabado negro brillante



Código	#Moletas	Dimensiones del porta herramienta de moleta (alto x ancho x largo)	Dimensiones de moleta (Ø x Ancho x Agujero)	Ventajas	MIN CAJA MASTER
SA-100-0090	1	12.7 x 12.7 x 100 mm	19 x 6.35 x 6.35 mm	Para aplicaciones de trabajo ligero	1 25 100
SA-100-0080	2	12.7 x 12.7 x 115 mm	19 x 9.52 x 6.35 mm	Para aplicaciones pequeñas de moletado, con cabeza ajustable	1 20 200
SA-100-0100	6	12.7 x 28 x 165 mm	19 x 9.52 x 6.35 mm	Hasta 3 patrones de moletado diferente sin cambiar la herramienta (fino, mediano y grueso)	1 6 24



Rueda para Moletador

Juegos de 2 piezas



Código	Características	MIN	CAJA	MASTER
SA-100-0110	Recto	1	10	600
SA-100-0120	Izquierdo 3/4"	1	10	600

ACCESORIOS PARA MAQUINADO

Porta Cuchilla Recta



Código	Medida	MIN	CAJA	MASTER
SA-150-0400	1/2"	1	15	150
SA-150-0410	5/8"	1	10	120
SA-150-0420	3/4"	1	8	64
SA-150-0430	7/8"	1	6	24
SA-150-0440	1"	1	6	150
SA-150-0442	1-1/8"	1	4	16

Porta Buril Uña de Cabra

Contrapesado para obtener acabados más suaves
Mecaniza superficies de hasta 6" de ancho con buril estándar
Acabado negro brillante
Incluye base de madera
No incluye buriles
Juego de 3 piezas



Código	Diámetro	Ø de zanco	Medida del buril que sujeta	MIN	CAJA	MASTER
SA-150-0350	3/4"	1/2"	3/16"	1	10	60
	1-1/8"	1/2"	1/4"			
	1-1/2"	1/2"	5/16"			
SA-150-0360	1-1/2"	3/4"	5/16"	1	4	16
	2"	3/4"	5/16"			
	2-1/2"	3/4"	5/16"			

Grapas de Sujeción

Ideal para sujetar piezas en máquina
Incluye: espigas (3", 4", 5", 6", 7" y 8" de largo - 4 de cada una)
Tuerca de acoplamiento
Tuerca en T 2 abrazaderas de paso por cada juego de espigas
Tuerca de brida
Bloque de escalones



Código	Rosca	Cabeza	Piezas
SA-105-0010	3/8"-16	1/2"	58
SA-105-0020	1/2"-13	5/8"	58
SA-105-0030	5/8"-11	3/4"	58



ACCESORIOS PARA MAQUINADO

Portaburil Zanco Recto

Corta en cualquier dirección

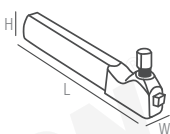

Código	Medida	Dimensiones (W x H x L)	MIN	CAJA	MASTER
SA-150-0450	1/4"	3/8 x 7/8 x 5"	1	15	60
SA-150-0490	5/16"	1/2 x 1-1/8 x 6"	1	10	40
SA-150-0530	3/8"	5/8 x 1-3/8 x 7"	1	6	24
SA-150-0560	1/2"	7/8 x 1-3/4 x 9"	1	4	16

Portaburil Zanco Derecho

Corta de derecha a izquierda

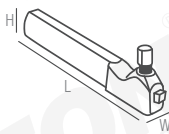

Código	Medida	Dimensiones (W x H x L)	MIN	CAJA	MASTER
SA-150-0460	1/4"	3/8 x 7/8 x 5"	1	15	90
SA-150-0480	5/16"	1/2 x 1-1/8 x 6"	1	10	60
SA-150-0500	3/8"	5/8 x 1-3/8 x 7"	1	6	24
SA-150-0540	1/2"	7/8 x 1-3/4 x 9"	1	4	16

Portaburil Zanco Izquierdo

Corta de izquierda a derecha

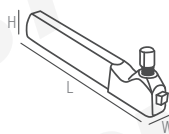

Código	Medida	Dimensiones (W x H x L)	MIN	CAJA	MASTER
SA-150-0470	1/4"	3/8 x 7/8 x 5"	1	15	90
SA-150-0510	5/16"	1/2 x 1-1/8 x 6"	1	8	32
SA-150-0520	3/8"	5/8 x 1-3/8 x 7"	1	5	20
SA-150-0550	1/2"	7/8 x 1-3/4 x 9"	1	4	16

Zanco para Boring



Código	Zanco	Rosca
SA-150-0020	R8	7/8"
SA-150-0030	R8	1-1/2"
SA-150-0040	ISO-40	1-1/2"

Cabezal Boring

Cuerda interior de 1-1/2"-18



DISPONIBLE
Barras boring compatibles
VER PÁG. 165



Código	Medida de cabezal	Largo Total	Para barra de	Set de barras compatible
SA-150-0050	2"	2-1/2"	1/2"	SA-150-0370 (9pzas)
SA-150-0060	3"	3-5/32"	3/4"	SA-150-0380 (12pzas)
SA-150-0070	4"	3-43/64"	1"	SA-150-0390 (7pzas)

Cabezal Boring Automático



Código	Medida de cabezal	Zanco
SA-150-0080	4"	R8

Sujetador para Boquilla Tipo D



Código	Descripción
SA-025-0334	Para boquilla 5C

Sujetador para Boquilla Tipo C



Código	Descripción
SA-025-0333	Para boquilla 5C

Sujetador de Porta Herramientas CNC



Código	Tipo	MIN	CAJA
SA-305-0350	#40	1	5
SA-305-0360	#50	1	5

Prensa Manual Tipo Chango



Código	Capacidad	Altura de prensa	Capacidad sobre mesa
SA-100-0300	1 T	12"	5 - 1/4"
SA-100-0310	2 T	17"	8 - 1/2"
SA-100-0320	3 T	21-1/2"	12 - 1/2"
SA-100-0330	5 T	Con matraca	-

Prensa para Taladro

Para taladrar, roscar, fresar y rectificar



Código	Mordaza	Altura de mordaza	Apertura máxima	MIN	CAJA
SA-050-0300	2 - 1/2"	16 mm	45 mm	1	-
SA-050-0310	3"	20 mm	50 mm	1	10

Prensa Pesada



Código	Mordaza	Apertura	Peso
SA-050-0320	100 mm	110 mm	8.7 kg
SA-050-0330	140 mm	150 mm	18 kg
SA-050-0340	200 mm	210 mm	38 kg

Prensa Tipo Kurt

Ideal para trabajos de precisión en centros de maquinados, fresadoras, taladros, rectificadoras. Cuenta con una precisión de 0.025mm/100mm (paralelismo y cuadratura)

Base giratoria

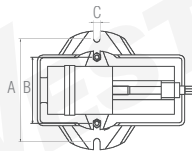

Código	Ancho de mordaza	Altura de mordaza	Apertura máxima	Peso bruto/peso neto	A	B	C
SA-050-0010	100mm (4")	32mm	100mm	14/13 kg	206mm	136mm	14mm
SA-050-0020	125mm (5")	40mm	125mm	21/20 kg	238mm	163mm	14mm
SA-050-0030	160mm (6")	45mm	170mm	33/32 kg	282mm	192mm	18mm
SA-050-0050	160mm (6")	45mm	200mm	33/32 kg	282mm	192mm	18mm
SA-050-0040	200mm (8")	50mm	230mm	46/45 kg	320mm	230mm	18mm

Prensa Tipo Kurt para CNC de Precisión



Código	Mordaza
SA-050-0060	4"
SA-050-0070	6"

Prensa Giratoria para Fresadora

Ideal para grandes trabajos de precisión

Fabricada de hierro fundido



Código	Ancho de mordaza	Profundidad de mordaza (mm)	Apertura máxima de mordaza (mm)
SA-050-0080	4"	35mm	80mm
SA-050-0090	6"	52mm	125mm
SA-050-0100	8"	63mm	160mm
SA-050-0110	14"	81mm	360mm
SA-050-0115	16"	85mm	430mm

Prensa Industrial



Código	Medida
SA-050-0160	4"

Prensa de Senos de Precisión

Ángulo 0° - 45° grados



Código	Mordaza	Apertura
SA-050-0210	2"	2-5/8"
SA-050-0220	3"	4"
SA-050-0230	4"	5"

Prensa de Redondos



Código	Mordaza
SA-050-0120	4"

Prensa Doble Acción

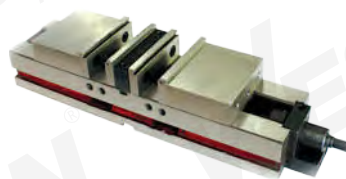

Código	Mordaza	Altura de mordaza	Apertura
SA-050-0260	4"	-	-
SA-050-0270	6"	2"	4"

Prensa Acción Rápida



Código	Mordaza
SA-050-0280	4"

ACCESORIOS PARA MAQUINADO

Presna de Coordenadas

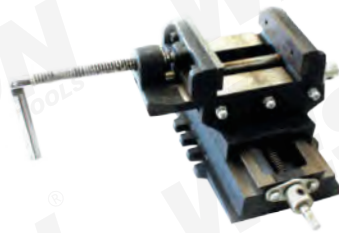

Código	Mordaza
SA-050-0290	4"
SA-050-0295	6"

Mesa de Coordenadas



Código	Medidas
SA-100-0270	6" x 12"

Presna Doble Ángulo Inclinable



Código	Mordaza
SA-050-0130	4"
SA-050-0140	6"

ACCESORIOS PARA MAQUINADO

Presna Universal Angular con 3 Movimientos

Fabricada en hierro fundido de alta calidad
 Precisión de presna: 0.025 mm/100 mm (paralelismo y cuadratura)
 3 ajustes angulares, rotación e inclinación de presna y base giratoria
 Se utiliza para trabajos de mecanizado y electroerosión de piezas complejas

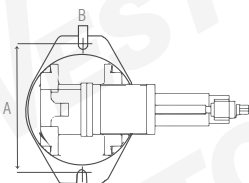

Presentación

Código	Ancho de mordaza	Profundidad de mordaza	Apertura máxima de mordaza	Peso Bruto/Neto	Dimensiones de montaje	
					A	B
SA-050-0150	4"	40 mm	105 mm	24 kg / 23 kg	246 mm	18 mm

Presna de Precisión



Código	Mordaza	Profundidad de mordaza	Apertura
SA-050-0170	2"	1-3/8"	7-1/2"
SA-050-0180	3"	1-5/8"	9"
SA-050-0200	6" para CNC		

Presna CNC para CAT y BT



Código	Descripción
SA-050-0350	Para CAT40 BT40
SA-050-0360	Para CAT50 BT50

Cabezal Divisor para Boquilla 5C



Código	Descripción
SA-025-0331	Para boquilla 5C

Chuck para Boquilla 5C



Código	Descripción
SA-025-0332	Para boquilla 5C

También contamos con...



Ver página 201

Mesa Rotativa Horizontal-Vertical

De gran desempeño
 Funciona como un centro índice en la posición vertical, así como una mesa rotativa convencional para corte circular, ajuste de ángulo y barrenar (boring)
 Mesa está hecha de Meehanite; base del cuerpo, superficie de la mesa y piezas giratorias con acabado molido que permite una suave rotación
 La relación es 90:1
 La mesa de trabajo se graduó en 360°, de modo que un giro de la manija mueva la tabla en 4

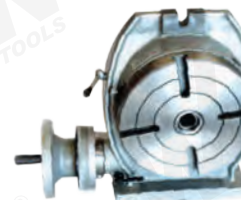
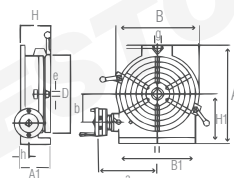

Medidas en mm

Código	Ø Exterior D	A1	Altura H	H1	Dimensión de base A	B	Ancho Ranura e	Tipo	g	Cono Morse
SA-100-0140	8"	3.94"	4.13"	5.31"	10.43"	8.66"	0.55"	⊕	0.67"	MT3
SA-100-0150	10"	4.33"	4.53"	6.50"	12.80"	11.02"	0.55"	⊗	0.67"	MT3
SA-100-0160	12"	5.04"	5.19"	7.68"	15.39"	12.99"	0.63"	⊗	0.71"	MT4
SA-100-0180	14"	5.04"	5.43"	9.06"	17.72"	15.35"	0.63"	⊗	0.71"	MT4

Mesa Rotativa Inclinable 12"

Doble utilidad vertical y horizontal con buenas capacidades de carga
Tornillo sinfin endurecido y rectificado para mayor durabilidad y precisión
Ambas caras de apoyo rectificadas
El accesorio ideal para las fresadoras
Carga máxima horizontal 250 kg
Carga máxima vertical 125 kg

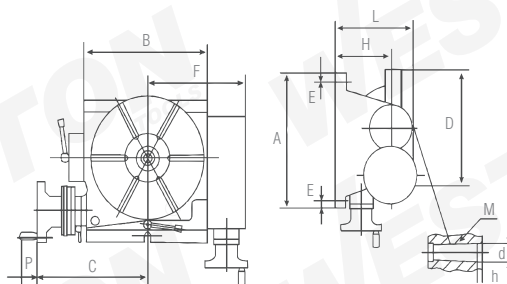

Presentación

Medidas en mm										
A	E	H	D	M	d	h	B	F	P	C
380	16	175	320	MT4	40	10	322	241	50	252

Código	Diámetro de la mesa	Cono morse central	Ancho de ranura T	Módulo de engranes	Ancho de la llave	Inclinación de la ranura T	Relación de engranes	Graduación de la mesa	Ángulo de la inclinación	Lectura del volante	Mínimo valor del vernier	Lectura mínima del vernier
SA-100-0170	12"	MT4	14 mm	2	18 mm	60°	1:125	360°	0°-90°	1'	10"	2'

Cabezal Divisor sin Chuck



Cabezal Divisor con Chuck

Con accesorios



Código	Modelo	Estilo	Volteo	Altura	Conicidad del cabezal	Peso
SA-100-0220	BS0	Semi-Universal	6-1/2"	4"	#7 B y S	45lb
SA-100-0230	BS1	Semi-Universal	9"	5"	#9 B y S	80lb
SA-100-0240	BS2	Universal	9-1/4"	5-3/8"	#10 B y S	175lb

Código	Modelo	Estilo	Volteo	Altura del centro	Cono morse del cabezal	Conicidad del cabezal	Ø del agujero del husillo	Chuck	Peso
SA-100-0190	BS0	Semi-Universal	6-1/2"	4"	MT2	#7 B y S	18mm	4"	20kg
SA-100-0200	BS1	Semi-Universal	9"	5"	MT3	#9 B y S	22mm	5"	33kg
SA-100-0210	BS2	Universal	9-1/4"	5-3/8"	MT4	#10 B y S	-	6"	65kg

Chuck Tipo Universal de 3 Mordazas

Dientes de las mordazas templados y rectificados
Cuerpo fabricado en acero fundido

Medidas en mm

Código	Diámetro (A)	B	C	D	E	F	Velocidad Máxima (r/min)
SA-125-0010	3"	55	16	66	50	12	4,000
SA-125-0020	4"	72	22	74.5	55	15	3,500
SA-125-0030	5"	95	30	84	58	16	3,000
SA-125-0040	6"	130	45	95	65	18.5	2,500
SA-125-0050	8"	165	65	113	75	22	2,000
SA-125-0060	10"	206	80	124	80	27	1,600
SA-125-0070	12"	260	100	141.5	90	36	1,200
SA-125-0080	15"	325	145	156	102.5	36	1,000
SA-125-0090	16"	340	145	155	101.5	36	1,000
SA-125-0100	20"	440	210	174	115.5	45	800



Incluye: Mordazas, tornillos y llave incluidos

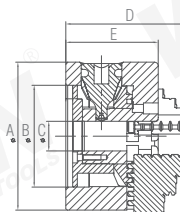
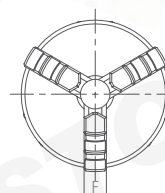

Presentación

Chuck para Torno Independiente de 4 Mordazas

Diseñados para agarre de piezas de trabajo de forma redonda o extraña

Medidas en mm

Código	Diámetro	D1	D3	H	H1	h	z-d	Velocidad Máxima (r/min)
SA-125-0120	4"	72	24	73.9	54	3.5	4-M8	3500
SA-125-0110	5"	95	30	78	56	4.5	4-M8	3000
SA-125-0130	6"	65	45	93	75	5	4-M10	2500
SA-125-0140	8"	80	56	107	80	6	4-M10	2000
SA-125-0150	10"	110	75	120	90	6	4-M12	1600
SA-125-0160	12"	140	95	134	90	6	4-M16	1200
SA-125-0170	14"	130	95	134	90	6	4-M16	1200
SA-125-0180	16"	160	125	143	95	8	4-M16	1000
SA-125-0190	20"	200	160	161	106	8	4-M20	800
SA-125-0200	25"	220	180	180	118	10	4-M20	600
SA-125-0210	32"	250	210	202	132	12	4-M20	500
SA-125-0220	40"	320	260	230	150	15	4-M20	400



Incluye: Mordazas, tornillos y llave incluidos

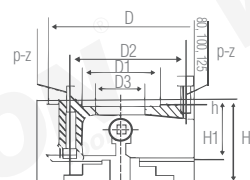

Presentación

Chuck para Torno Universal de 4 Mordazas

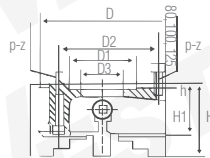

Medidas en mm

Código	Diámetro	D1	D2	D3	H	H1	h	z-d	Presentación
SA-125-0240	6"	130	142	40	95	65	5	3-M8	
SA-125-0250	8"	165	180	65	109	75	5	3-M10	
SA-125-0260	10"	206	226	80	120	80	5	3-M12	
SA-125-0270	12"	272	296	100	154.5	96	12	3-M16	
SA-125-0280	16"	325	350	135	155.5	98	6	3-M16	
SA-125-0290	20"	440	465	210	202	115	6	6-M16	

Chuck para Torno Universal de 6 Mordazas



Código	Diámetro
SA-125-0230	10"

ACCESORIOS PARA MAQUINADO

Chuck Universal Automático 2405



Chuck Delgado



Acero de alta calidad

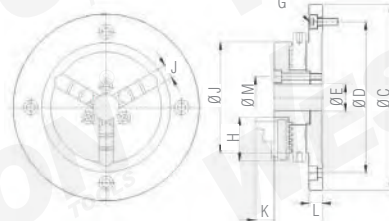

Código	Ø	BISON	Equivalente	Código	Medida	A	C	D	E	G	H	J	K	L	M	Ø Diámetro de agarre	L	M	Peso
SA-500-0630	16"	2405-400-120K	3-781-1511	SA-500-2520	2.48"	63	118	100	16	4-M5x0.8P	27	8	13	13	13	0.8-63	23-58		1.2kg

Juego de 3 Mordazas Universal Internas y Externas



Juego de 4 Mordazas Universal Internas y Externas

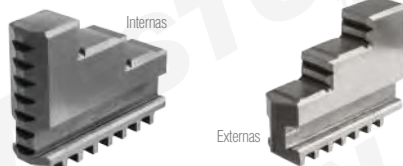

Internas	Externas	Medida	Chuck compatible
SA-126-0040	SA-127-0040	6"	SA-125-0040
SA-126-0050	SA-127-0050	8"	SA-125-0050
SA-126-0060	SA-127-0060	10"	SA-125-0060
SA-126-0070	SA-127-0070	12"	SA-125-0070
SA-126-0090	SA-127-0090	16"	SA-125-0090
SA-126-0100	SA-127-0100	20"	SA-125-0100

Internas	Externas	Medida	Chuck compatible
SA-126-0240	SA-127-0240	6"	SA-125-0240
SA-126-0250	SA-127-0250	8"	SA-125-0250
SA-126-0260	SA-127-0260	10"	SA-125-0260
SA-126-0270	SA-127-0270	12"	SA-125-0270
SA-126-0280	SA-127-0280	16"	SA-125-0280
SA-126-0290	SA-127-0290	20"	SA-125-0290

Juego de 4 Mordazas Independiente



Chuck Magnético Rectangular



Ofrece una óptima sujeción para las piezas con muy poco espesor
Recomendado para todas las operaciones clásicas de rectificado

Internas	Medida	Chuck compatible
SA-126-0130	6"	SA-125-0130
SA-126-0140	8"	SA-125-0140
SA-126-0150	10"	SA-125-0150
SA-126-0160	12"	SA-125-0160
SA-126-0170	14"	SA-125-0170
SA-126-0180	16"	SA-125-0180
SA-126-0190	20"	SA-125-0190

Juego de clamps incluidos



Código	Tamaño	Altura del chuck	Espacio entre polos	Fuerza de retención	Peso
SA-305-0070	6" x 12"	48 mm	1.5 + 0.5 mm	145 - 174 PSI	18 kg
SA-305-0080	6" x 18"	53 mm	1.5 + 0.5 mm	145 - 174 PSI	30 kg

Chuck Magnético Redondo

Sujeta piezas de trabajo en afiladoras, tornos u otras máquinas que tengan husillos giratorios
Tamaño de agujero: (4) 3/8" - 16 x 1/2"



WESTON
TOOLS

Accesorio para Radios

Máximo arco de afilado 30°.



WESTON
TOOLS

Formador de Punzones Ajuste Vertical y Horizontal

El formador de punzones se puede usar en rectificadoras de superficie o universales para rectificar puntos redondos, radiales y múltiples ángulos



WESTON
TOOLS

Código	Diámetro	Ancho	Contorno	Distancia entre seguros
SA-305-0090	10"	3"	4" x 3/16"	5"

Código	Descripción
SA-100-0255	Boquilla 5c

Código	Descripción
SA-100-0060	

Formador de Punzones

El formador de punzones se puede usar en rectificadoras de superficie o universales para rectificar puntos redondos, radiales y múltiples ángulos

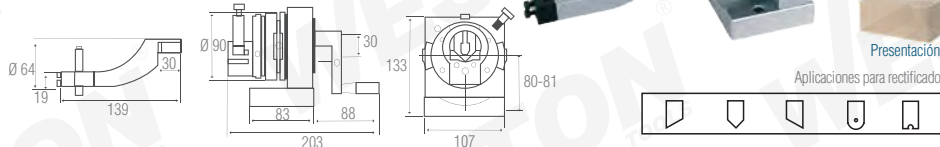

Código	Tipo de ajuste	Rango de rectificaco Convexo	Rango de rectificaco Cóncavo	Altura del centro	Viaje del bloque	Tamaño máximo de rueda de rectificaco
SA-100-0070	Ajuste Horizontal	R50 mm	R100 mm	80 mm	V 25 mm	Ø 200 mm

WESTON
TOOLS

Escoplo

Conexión trifásica 220V
Cambio de velocidades por banda
Diámetro máximo de barra 5/8"



WESTON
TOOLS

Código	Carrera	Motor
SA-100-0010	4"	250 W
SA-100-0020	5"	370 W

Mesa Inclinable



WESTON
TOOLS

Código	Medida
SA-100-0280	6 x 12"
SA-100-0290	10 x 15"
SA-100-0130	12"

Plato Angular Sólido



WESTON
TOOLS

Código	Medida
SA-100-9920	4"
SA-100-9930	6"
SA-100-9940	8"
SA-100-9950	12"

Plato Angular Sólido con Ranuras



WESTON
TOOLS

Código	Medidas	MIN	CAJA	MASTER
SA-100-9960	6" x 5" x 4-1/2"	1	4	16
SA-100-9970	6" x 5" x 4-1/2"	1	6	-
SA-100-9980	8" x 6" x 5"	1	2	-
SA-100-9990	12" x 9" x 8"	1	-	-

Torreta Cambio Rápido para Torno



WESTON
TOOLS

Código	Medida	Piezas
SA-150-0270	10-15"	5
SA-150-0280	12"	5
SA-150-0290	13-18"	5
SA-150-0300	14-20"	5

Cuña de Expulsión



WESTON
TOOLS

Código	Medida
SA-150-0310	#1
SA-150-0320	#2
SA-150-0330	#3
SA-150-0340	#4

Perillas



WESTON
TOOLS

Código	Medida	Tipo	MIN	CAJA	MASTER
SA-250-0020	1/4"-20	Redonda	1	50	600
SA-250-0030	3/8"-16	Redonda	1	50	300
SA-250-0040	1/4"-20	Estrella	1	50	900
SA-250-0050	5/16"-18	Estrella	1	50	600
SA-250-0060	3/8"-12	Estrella	1	50	300
SA-250-0070	1/2"-13	Estrella	1	50	200

ACCESORIOS PARA MAQUINADO

Ancla para Máquina



Código	Medida	Capacidad	Rosca
M-02050	86 x 20mm	800kg	M12
M-02060	120 x 30mm	1 500kg	M16
M-02070	150 x 30mm	2 000kg	M16
M-02080	200 x 35mm	3 500kg	M20

Gato Mecánico para Equilibrar

Para nivelar piezas de trabajo



Código	Rango	Capacidad de carga	Base	MIN CAJA MASTER
SA-250-0010	3" a 4"	450 kg	Ø 37mm	1 12 156

Avance Automático

Motor de 110V/60Hz
Con control de velocidad variable



Código	Eje	Torque	Máx. RPM	MIN	CAJA
M-00230	X	310 LB	200	1	4
M-00240	Y	310 LB	200	1	4
M-00250	X	500 LB	180	1	4

ACCESORIOS PARA MAQUINADO

Yunque

Fabricado en hierro fundido

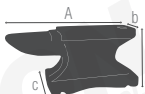

Código	Peso	A	b	c	d
M-02320	55 Lb	14-1/4"	4"	6"	6-1/2"
M-02330	100 Lb	17-1/2"	5-1/2"	8"	8"

Carrito Porta Herramientas CNC

Fabricado en acero de alto calibre con bandejas en ángulo que permiten un rápido acceso a las herramientas
Ruedas de trabajo pesado de 5" x 1-1/4" con capacidad de carga de 1000 lb (45.35kg)
Insertos de nailon para proteger las herramientas



Carrito cono 50 huot SA-305-0110

Código	Espacios	Cono	Tipo
SA-305-0110	36	50	BT, CAT-V, NMTB
SA-305-0100	48	40	BT, CAT-V, NMTB

Tornillo de Banco Tipo Wilton Tradesman

Base giratoria de 360°



Código	Mordaza	Apertura	Profundidad de garganta
M-02300	4-1/2"	114.3 mm	90 mm

Tornillo de Banco Pesado Tipo Wilton

Base giratoria de 360°



Código	Mordaza	Apertura	Profundidad de garganta
M-02260	4"	108 mm	87 mm
M-02270	5"	133 mm	95 mm
M-02280	6"	152 mm	105 mm
M-02290	8"	216 mm	114.5 mm

Tornillo de Banco Multiusos

Base giratoria de 360°
Cuerpo de hierro fundido
Distancia de agujeros de la base 15mm
Distancia entre agujeros de la base 192 mm



Mordaza giratoria para tubería



Yunque incorporado 80x97mm



Presentación

Código	Ancho De mordaza	Apertura de mordaza	Profundidad de mordaza	Fuerza de sujeción	Peso
M-02310	5-1/2" (140 mm)	125 mm	82.5 mm	2 500 kg	27.75kg

WESTON



ESCANEA PARA VER VIDEO

Tornillo de Banco

Base giratoria de 360°
Cuerpo de hierro fundido
Yunque incorporado



Presentación

Código	Ancho De mordaza	Apertura de mordaza	Profundidad de mordaza	Fuerza de sujeción	Peso Neto	Yunque
M-02200	4"	75mm	50mm	1 500 kg	5.5 kg	63 mm x 66 mm
M-02210	5"	100mm	60mm	2 000 kg	9.2 kg	80 mm x 80 mm
M-02220	6"	125mm	68mm	2 500 kg	13.2 kg	90 mm x 90mm

Tornillo de Banco Ligero

Base giratoria de 360°
Cuerpo de hierro fundido
Yunque incorporado



Presentación

Código	Ancho De mordaza	Apertura de mordaza	Profundidad de mordaza	Fuerza de sujeción	Peso Neto	Yunque	MIN CAJA
M-02230	3"	63.5 mm	45 mm	1 000 kg	3.7 kg	50 mm x 60 mm	1 2
M-02240	4"	100 mm	67 mm	1 500 kg	9.5 kg	51 mm x 56 mm	1 2
M-02250	5"	125 mm	75 mm	2 000 kg	12.8 kg	61 mm x 63 mm	1 -

Calzas para Motores y Máquinas

Incluye estuche



1/16" - 24 piezas
1/64" - 48 piezas
1/32" - 48 piezas
1/8" - 24 piezas



Código	Contenido	MIN	CAJA
A-16460	144 Piezas	1	12

Juego de Calza de Acero Inoxidable

Para nivelar motores, bombas, compresores y maquinaria en general. Reduce los paros por mantenimiento. Económicas y fáciles de utilizar, pues no necesitan cortarse. Medidas: 0.001" - 0.125"

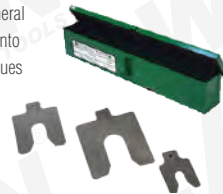

Código	Ranura	Tamaño	Piezas
PB-42900	5/8"	2" x 2"	260
PB-42910	7/8"	3" x 3"	260
PB-42940	5/8"	2" x 2"	130
PB-42950	7/8"	3" x 3"	130

Juego de Punzones y Dados

El juego de troqueles y punzones autocentrantes hace arandelas, calzas y juntas perfectas y personalizadas en segundos.

9 tamaños de punzón: 1/8", 3/16", 1/4", 5/16", 3/8", 7/16", 1/2", 5/8" y 3/4".

8 tamaños de piloto de DI: 1/8", 3/16", 1/4", 5/16", 3/8", 7/16", 1/2" y 5/8".

Corta acero, latón, cobre, aluminio, caucho y plástico sin esfuerzo de hasta 0.025" de espesor y acero inoxidable/acero templado azul hasta 0.010" de espesor.



Código	Características
PB-40110	Medidas fraccionales

Laina de Latón en Rollos

Dureza total, roladas en frío, aleación CDA 260

Fuerza ténsil aproximada 67,000 PSI



Código	Modelo	Medida
PB-17S1	17135	0.001" x 6" x 100"
PB-17S1X	17160	0.0015" x 6" x 100"
PB-17S2	17195	0.002" x 6" x 100"
PB-17S3	17240	0.003" x 6" x 100"
PB-17S4	17265	0.004" x 6" x 100"
PB-17S5	17305	0.005" x 6" x 100"
PB-17S6	17330	0.006" x 6" x 100"
PB-17S7	17355	0.007" x 6" x 100"
PB-17S8	17370	0.008" x 6" x 100"
PB-17S10	17415	0.010" x 6" x 100"
PB-17S12	17445	0.012" x 6" x 100"
PB-17S15	17475	0.015" x 6" x 100"
PB-17S20	17495	0.020" x 6" x 100"
PB-17S25	17515	0.025" x 6" x 100"
PB-17S31	17535	0.031" x 6" x 100"



Laina de Acero Inoxidable en Rollos

Dureza total, roladas en frío, tipo 302. Fuerza ténsil aproximada de 185,000 PSI



Código	Modelo	Medida
PB-22L1	22125	0.001" x 6" x 50"
PB-22L1X	22126	0.0015" x 6" x 50"
PB-22L2	22150	0.002" x 6" x 50"
PB-22L3	22175	0.003" x 6" x 50"
PB-22L4	22195	0.004" x 6" x 50"
PB-22L5	22220	0.005" x 6" x 50"
PB-22L7	22260	0.007" x 6" x 50"
PB-22L8	22285	0.008" x 6" x 50"
PB-22L10	22320	0.010" x 6" x 50"
PB-22L12	22340	0.012" x 6" x 50"
PB-22L15	22365	0.015" x 6" x 50"
PB-22L20	22390	0.020" x 6" x 50"
PB-22L25	22410	0.025" x 6" x 50"
PB-22L31	22430	0.031" x 6" x 50"
PB-22980	22980	0.80mm x 150mm x 1.25m



Laina de Acero en Rollos

Dureza total, roladas en frío, bajo carbón 1010

Fuerza ténsil aproximada 80,000 PSI



Código	Modelo	Medida
PB-16A1	16130	0.001" x 6" x 100"
PB-16A1X	16155	0.0015" x 6" x 100"
PB-16A2	16195	0.002" x 6" x 100"
PB-16A3	16245	0.003" x 6" x 100"
PB-16A4	16280	0.004" x 6" x 100"
PB-16A5	16320	0.005" x 6" x 100"
PB-16A6	16345	0.006" x 6" x 100"
PB-16A7	16370	0.007" x 6" x 100"
PB-16A8	16395	0.008" x 6" x 100"
PB-16A9	16415	0.009" x 6" x 100"
PB-16A10	16450	0.010" x 6" x 100"
PB-16A12	16480	0.012" x 6" x 100"
PB-16A15	16530	0.015" x 6" x 100"
PB-16A18	16560	0.018" x 6" x 100"
PB-16A20	16590	0.020" x 6" x 100"
PB-16A25	16630	0.025" x 6" x 100"
PB-16A31	16660	0.031" x 6" x 100"
PB-16AA1	16140	0.001" x 12" x 120"
PB-16AA4	16290	0.004" x 12" x 120"
PB-16AA5	16330	0.005" x 12" x 120"
PB-16AA6	16355	0.006" x 12" x 120"
PB-16AA8	16405	0.008" x 12" x 120"
PB-16AA10	16460	0.010" x 12" x 120"
PB-16AA12	16490	0.012" x 12" x 120"
PB-16AA15	16540	0.015" x 12" x 120"
PB-16AA18	16570	0.018" x 12" x 120"
PB-16AA20	16600	0.020" x 12" x 120"

Laina de Acero en Rollos Métrica

Dureza total, roladas en frío, aleación CDA 260

Fuerza ténsil aproximada 67,000 PSI



Código	Modelo	Medida
PB-16971	16971	0.05mm x 150mm x 2.5m
PB-16972	16972	0.10mm x 150mm x 2.5m
PB-16973	16973	0.15mm x 150mm x 2.5m
PB-16974	16974	0.20mm x 150mm x 2.5m
PB-16975	16975	0.25mm x 150mm x 2.5m
PB-16976	16976	0.30mm x 150mm x 2.5m
PB-16977	16977	0.40mm x 150mm x 2.5m
PB-16978	16978	0.50mm x 150mm x 2.5m
PB-16979	16979	0.65mm x 150mm x 2.5m
PB-16980	16980	0.80mm x 150mm x 2.5m



Juego de Lainas Calibradoras 1/2" x 12"

Usadas en operaciones de producción y mantenimiento en donde se requiera medir una tolerancia o ajuste de apriete.

Contenido: 20 piezas



Código	Medidas
PB-19G40	0.001" 0.007" 0.016"
	0.0015" 0.008" 0.018"
	0.002" 0.009" 0.020"
	0.003" 0.010" 0.022"
	0.004" 0.012" 0.025"
	0.005" 0.014" 0.030"
	0.006" 0.015"



Juego de Lainas Calibradoras 1/2" x 5"

Usadas en operaciones de producción y mantenimiento en donde se requiera medir una tolerancia o ajuste de apriete.

Contenido: 20 piezas



Código	Medidas
PB-19G20	0.001" 0.007" 0.016"
	0.0015" 0.008" 0.018"
	0.002" 0.009" 0.020"
	0.003" 0.010" 0.022"
	0.004" 0.012" 0.024"
	0.005" 0.014" 0.025"
	0.006" 0.015"



SUMINISTROS PARA MAQUINADO

Juego de Lainas de Acero 6" x 12"



Espesores: 0.001", 0.0015", 0.002", 0.003", 0.004", 0.005", 0.006", 0.007", 0.008", 0.010", 0.012", 0.015", 0.020", 0.025" y 0.031"

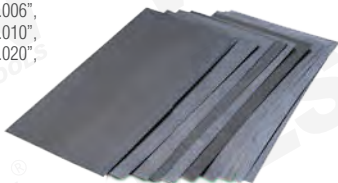

Juego de Lainas de Acero Inoxidable 6"X12"



Espesores: 0.001", 0.002", 0.003", 0.005", 0.008", 0.010", 0.015", 0.020"

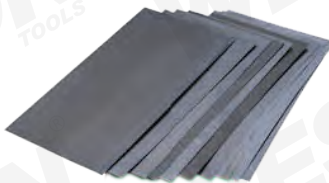

Juego de Lainas de Latón 6" x 12"



Espesores: 0.001", 0.0015", 0.002", 0.003", 0.004", 0.005", 0.006", 0.007", 0.008", 0.010", 0.012", 0.015", 0.020", 0.025" y 0.031"

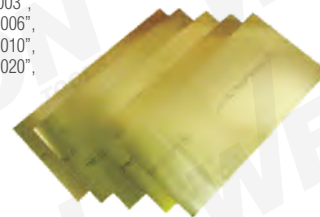

Código PB-16AF15 **Contenido** 15 piezas

Código PB-22LF8 **Contenido** 8 piezas

Código PB-17SF15 **Contenido** 15 piezas

SUMINISTROS PARA MAQUINADO

También contamos con...



HERRAMIENTAS DE MEDICIÓN
Dasqua

Ver página 175